

FarragTech offers a wide variety of material handling equipment in cooperation with ICEVA, the leading Swedish equipment manufacturer, insuring best quality and highest reliability based on many years of experience in the plastics market.

Single Loaders of the GS-Series are available in 2 sizes (4 l and 10 l) and in different versions. All versions are made of mirror stainless steel with hinged head for to facilitate cleaning.

The GS-Series is designed as a modular construction in 4 main parts:

The lower section includes the receiver with a mounting flange (4 holes for M6 bolts on a pattern Ø of 174 mm) at the bottom and a clamp ring at the top. It includes the material receiver with flap gate a magnetic switch and controller mounts. This section is available in 2 sizes (4 l and 10 l).

The middle section includes the suction connection (s) and the filter. This section is available in 2 different versions with a single suction connection or with a mixer valve configuration (VB version). It is coupled to the lower section by clamp ring.

The upper section is available in 2 different versions. The standard version includes a vacuum pump, a drive motor, the rotating self cleaning nozzle for the filter in the lower section and compressed air solenoid valve. The optional version includes a pneumatic valve, air connection to an external vacuum pump and the self cleaning components. This section is connected to the middle section through a hinge and latch to ease cleaning the filter without removing any part of the loader.

The controller is mounted on the mounts of the lower section. It switches the vacuum pump on and off and governs the suction cycle, the filter cleaning cycle and the mixing cycle. It also alarms in case of malfunction with strobe light and alarm message on the LCD display. All cycles and delay timers are manually adjustable. **All parts are exchangeable between the different types and sizes.**

The left illustration shows GS-4m for loading a single material with integrated vacuum pump and a 1.1 kW drive motor. It is capable of loading 100 kg of plastic resins to a horizontal distance of 5 m and 4 m elevation.

Exchanging the middle section converts the single loader into proportional loader with mixing chamber and pneumatic valves (GS-4m BV) as shown to the right of the illustration. The loader is shown with the optional CAMLOCK quick material hose couplings.

Exchanging the upper section may convert the loader into material cyclone (material separator) with external pump (GS-4m VP) as shown next.



Many accessories such as suction pipes, flexible hoses and adaptors for installation on extruder flange are available.

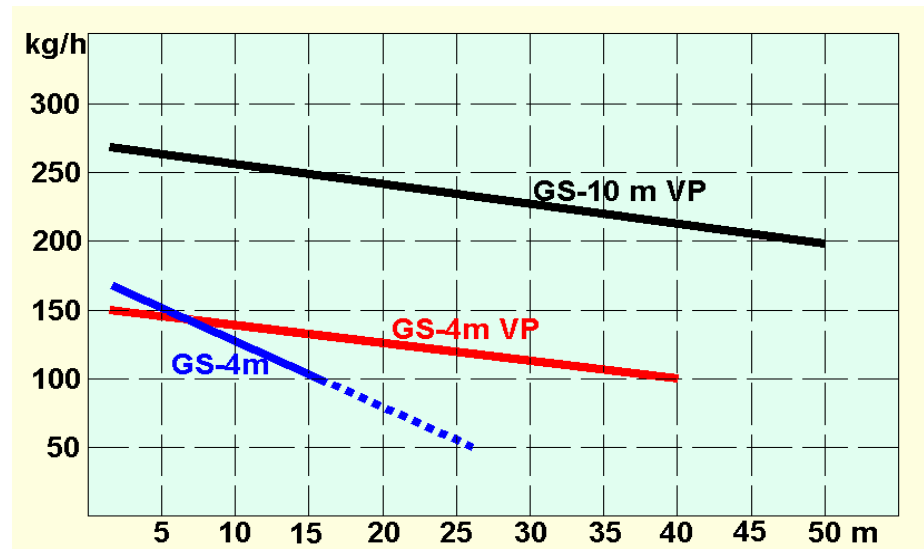

The performance diagram for the GS-Series is based on PE resin with bulk density of 0.65 kg/l and loading height of 4 m. External vacuum pumps with 0.75 – 2.2 kW motor are used with VP version.

| | GS-4m | GS-4m BV | GS-4m VP | GS-4m BV VP |
|----------------------------|----------------------|--------------|----------------------|--------------|
| Loader type | Mono | Proportional | Mono | Proportional |
| Vacuum pump | Integrated | Integrated | External | External |
| Hopper capacity (l)* | 4 | 4 | 4 | 4 |
| No of hose connections | 1 | 2 | 1 | 2 |
| Connection size (mm) | 38 | 38 | 38 | 38 |
| Installed power (W) | 1150 | 1150 | 800 | 800 |
| Ø excluding pipes (mm) | 202 | 202 | 202 | 202 |
| Height (mm)** | 567 | 567 | 456 | 456 |
| Weight (kg) | 9.6 | 11.1 | 7.3 | 8.8 |
| Power supply (V/Phases/Hz) | 115/1/60 or 230/1/50 | | 400/3/50 or 480/3/60 | |
| Compressed air (bar) | 5 - 8 | | | |

(*) Hopper capacity of **GS-10 m** is 10 l

(**) The height of **GS-10 m** is extended by 250 mm (+ 1.8 kg)

The **GS-Series** is also available for **CARD** dryer applications without control box (see *Resin Drying Data Sheets*).

The **FIT** controller of **CARD** dryers is programmed to control to loaders of the **GS-Series**. The alarms are shown on the display of the **FIT** controller. Only a small switch box including a contactor is provided with the loader in this case.

The power supply and the compressed air required for cleaning the filter may be provided in the dryer version (**GS-4m D** or **GS-10m D**) through the dryer or through external supplies but the control signals are always provided from the dryer controller. Therefore the “**D**” version can only be used to load material into a **CARD** dryer. An unloading version is also available to unload and transfer dried material from the dryer to the processing machine.

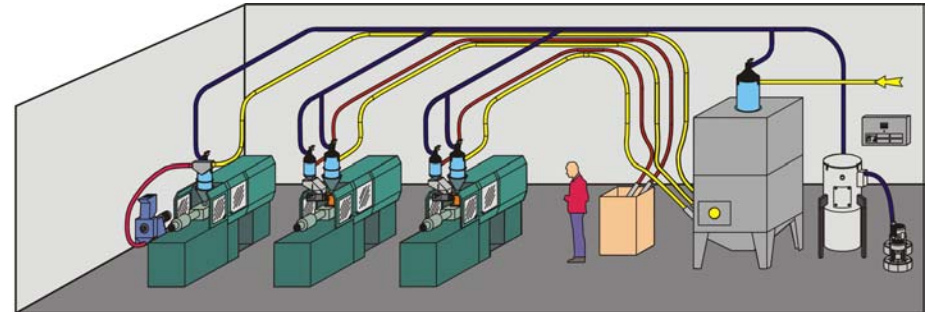

Six material cyclones with capacities of 2 l, 4 l, 10 l, 20 l, 40 l and 70 l are available. The material and air supply connections are mainly 50 mm. Optional **CAMLOCK** quick material hose couplings, many accessories and different cyclone mounts are available.

Venturi Loaders are simpler, low cost single loaders. Vacuum is created by a Venturi nozzle and compressed air to load material from a near by source to the destination. They have no moving parts and they virtually require no maintenance. They are therefore less troublesome in operation and they may be a good option to transfer smaller quantities of materials, additives or masterbatch.



The **MC-Series** of material cyclones are similar to the single loader **GS-m BV** but no controller is included as central control units are governing all the cyclones of the system.

Modular coupling stations provide flexibility in production plants.



The SF-Series of central filter units with automatic filter cleaning and by pass valve include:

- SF-Compact with a single filter cartridge and a plastic bag dust container
- SF-3 with 3 filter cartridges and a plastic bag dust container
- SF-10 with 6 filter cartridges, a 100 l metal bin on casters and a vacuum meter



The brain of the central system is the control unit:



- SP-Duo to control 2 main cyclones
- SP-Compact to control 4 or 10 main cyclones
- SP-32 to control up to 32 main cyclones

Central vacuum pumps with electrical motors from 0.75 kW to 11 kW are standard and other sizes are available on request.

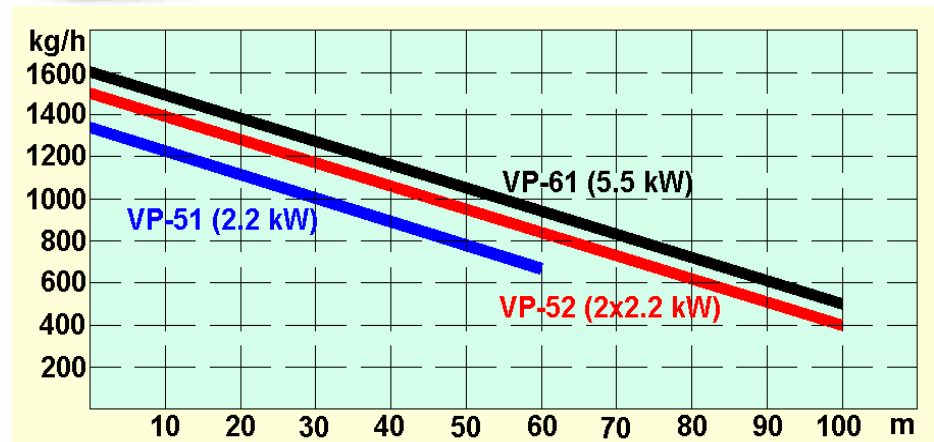

Plumbing is important in central loading systems. All components such as pipes, bends, connectors, flexible hoses, pick up wands, pipe cleaning valves and external mixing valves are available.



Volumetric blenders are important components in many applications. Mixing additives and masterbatch with plastics directly on extruder inlets is the best way to insure good product quality. *COLORFEED*, the low cost volumetric blenders, are available in 2 sizes (CF-380 and CF-500) with different screws, hoppers and motors to cover almost all blending needs. Up to 4 units for different additives can be installed on one neck-piece to fit on an extruder flange allowing for main material free fall feeding directly into the neck-piece. The additives are blended homogeneously with the main material before it enters the extruder. Model CF-380 is shown with performance data.



| Screw / sleeve (mm) | Power (W) | Blending capacity range (kg/h) |
|---------------------|-----------|--------------------------------|
| 5 / 12 | 12 | 0.02 - 0.70 |
| 8 / 14 | 12 | 0.05 - 1.75 |
| 8 / 16 | 12 | 0.08 - 2.70 |
| 8 / 18 | 12 | 0.17 - 4.20 |
| 12 / 18 | 12 | 0.17 - 4.70 |
| 12 / 18 | 24 | 0.36 - 13.0 |
| 12 / 20 | 24 | 0.50 - 20.0 |
| 16 / 26 | 24 | 1.00 - 30.0 |

Data based on HDPE, Ø 3 mm (0.95 g/cm³)

Colorfeed is easy to clean. Changing screws and hopperstrokes only a few seconds.



Gravimetric Blenders are much more accurate than volumetric blenders, thus saving money and paying back in short time. *COLORSAVE* is developed by *LIAD*, the leader in advanced dosing. The loss in weight method used in this technology guarantees high dosing accuracy directly on the inlet of the extruder. Up to 4 additives can be accurately blended with the main material, which can be weighed in continuous extruding processes. The system can also govern the extruder speed in such cases guaranteeing constant production and highest quality.

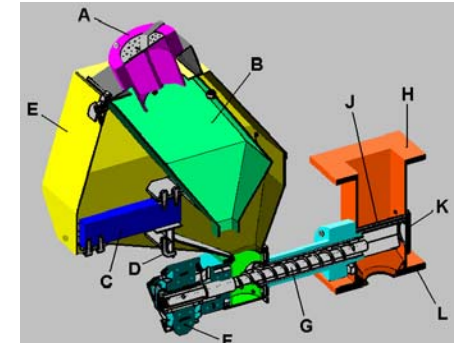

The ColorSave 1000 series is equipped with venturi loader (A) to transfer the additive into the weighing (B) inside the protective housing (E). The accurate load cell (C) weighs the additive in the hopper and observes the loss in weight when additive is blended with the main material in the neck piece (H). Different screw sizes (G) are available for any output required. The powerful *LENZE* motor and drive (E) runs the screw at a defined speed to divide the additive amount over filling time every cycle or adjust the speed in a continuous extrusion application.



Due to continuous development in all business aspects, *FarragTech* reserves all rights to modify designs and specifications without prior notice or any obligations.